

AC166 Series

Premium, Negative Voltage Accelerometer, Side Exit 3 Pin Connector, 100 mV/g, ±5%



VIBRATION ANALYSIS HARDWARE



Product Features

Comparable to Bently™ 330400

Three-Wire, Negative-Voltage Sensor

- ▶ 100 mV/g Nominal Sensitivity
- ▶ ± 5% Sensitivity Tolerance
- ▶ ± 80 g, Peak Dynamic Range

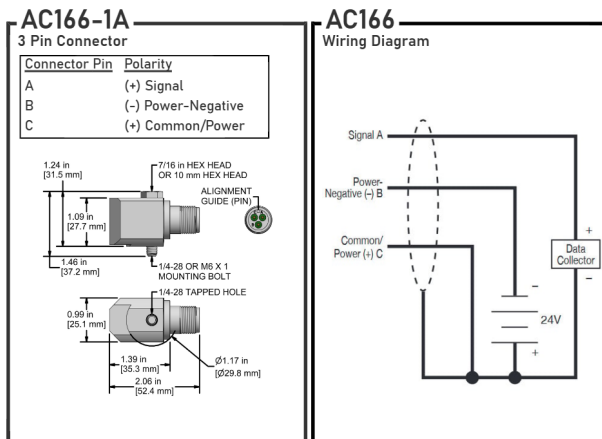

Specifications	Standard	Metric	Specifications	Standard	Metric
Part Number	AC166	M/AC166	Environmental		
Sensitivity (±5%)	100 mV/g		Operating Temperature Range	-58 to 250 °F	-50 to 121 °C
Frequency Response (±3dB)	300-600,000 CPM	5-10000 Hz	Maximum Shock Protection	5,000 g, peak	
Dynamic Range	± 60 g, peak		Sealing	Welded, Hermetic	
	*Vsource ≤ -20V, 8.5Vbias		SIL Rating	SIL 2	
Electrical			Physical		
Settling Time	<2 Seconds		Sensing Element	PZT Ceramic	
Voltage Source	-20 to -28 VDC		Sensing Structure	Shear Mode	
Constant Current Excitation	<1 mA		Weight	5.1 oz	145 grams
Broadband Noise Floor (10 to 15k Hz)	.002 g RMS		Case Material	316 Stainless Steel	
Output Impedance	<5 ohm		Connector (Non-Integral)	3 Pin MIL-C-5015	
Bias Output Voltage	-8.5 VDC Nominal		Resonant Frequency	1,320,000 CPM	22000 Hz
Case Isolation	>10 ⁸ ohm		Mounting Torque	2 to 5 ft. lbs.	2,7 to 6,8 Nm
			Mounting Hardware Supplied	1/4-28 Captive Bolt	M6x1 Captive Bolt
			Calibration Certificate	CA10	

Typical Frequency Response

